



Guiding Spirit to Shipping Industry

Sagar Sandesh

Maritime Tabloid English Weekly Thrice E - Paper

In association with R L Institute of Nautical Sciences, Madurai, Tamil Nadu. | RNI No. TNENG/2012/41759 | Wednesday, March 01, 2023 | Voyage 12 Wave 007

Published & Released on Every Monday, Wednesday and Friday



PAGE - 2

MASSA Academy
Chennai pioneers
to deliver Gas
fuelled



PAGE - 5

Shipping
Hedge Fund
Says Industry
Set For



PAGE - 6

Inauguration
of Container
Feeder



PAGE - 9

Invest in the
next growth
story at JNPA
SEZ

IME(I) – INA set up Centre of Cooperation to address the growing need of maritime technology

A Centre-of-Cooperation to address the growing need of national maritime technology advancement has been established between The Institute of Marine Engineers (India) and the Institution of Naval Architects (INA) at the IME(I) House Nerul last month.

The Centre was inaugurated by Prof. R.P. Gokarn, Retd. Prof. Head (NA & ME) & Dean Academics IIT Kharagpur & Retd. Prof. IMU, and a consultant to OERC during its formative years. The Centre was inaugurated by the traditional 'lighting the lamp', ushering in an era in pursuit of knowledge by Marine Engineers and Naval Architects. The two professional bodies have been collaborating in the past by holding INMARCO-INAvation conferences in 2010 and 2014 and working to support the various endeavours by the industry and government over many years. Among those physically attending the event included other eminent Maritime professionals e.g. Shri M. V. Ramamurthy, Shri Arun Kumar Gupta, Shri Rajeev Nayyar, Cmde. Bhupesh Tater (Retd.), Shri Sahai Raj, Shri Naresh Chugh, Shri Ashwini Kumar, Shri A. J. Das, Shri Avinash Upadhye, Shri H. V. Ramesh etc.

In the brief introductory speech before the technical session that followed the inauguration Mr. **J. Dasgupta, President of INA** gave a brief background of the initial discussions between the two professional bodies. He thanked IME(I) for taking the initiative and assured that this Centre

of Cooperation will sincerely endeavour to support maritime industry in design and construction for efficient and safe operation of ships and other maritime units. **The Centre was dedicated to the young future generation of maritime technical professionals who would have to stand up and take the responsibility to carry the torch for bigger achievements.**

The Technical Session following the inauguration was chaired by Prof. R. P. Gokarn consisted of

Turn to page -2 >>



Eastaway



**Best Employer for
Container Fleet
Seajob Indian Anchor
Awards- 2022**



Eastaway owns a diverse global fleet of 58 container vessels. Eastaway entered into a shipbuilding contract for 29 container ships, delivery commenced from September 2022 onwards & to be completed in 2 years timelines.

COMPANY BENEFITS :

1. Quick placement
2. Insurance for INDIAN officers and their immediate family
3. WI-FI on board for all ranks
4. Wages on time before month end and to market standards

Urgent requirements.

**2nd Officer, 3rd Officer, 3rd Engineer, and 4th Engineer.
EL/Off - COC/ Non-COC Holders (Extra Allowance for Crane exp)
Bosun / Cook (USD1700) AB / Oiler with COP (USD 1400)
Candidates should have container experience.**

Eastaway (India) Private Limited

RPSL: MUM-162104 / DOI: 24 May 2022 / DOE: 24 May 2027

Address: C- 421/422, Atrium 215, Andheri Kurla Road, Andheri (E), Mumbai- 400 069

Board line: +91 22 6802 0000 Mobile : +91 99200 75887/ 86579 17013

Email: seajobs@eastaway.com/ www.eastaway.com

IME(I) – INA set up..... From Page : 1

two excellent presentations in Hybrid Zoom format. The first presentation by **Shri Avinash Upadhye**, Head, International Business Development (Defence and Aerospace), L&T covered “Genesis, Evolution and Future of Integrated Electric Propulsion” wherein the author discussed electric propulsion in naval ships across the globe, the difficulties faced by various navies and how Indian designers are addressing and circumventing the issues to achieve better reliability and efficiency for differing missions.

The second session was a very interesting presentation by **Shri Arun Kumar Gupta**, Chairman IME(I) Mumbai Branch & Ex. CMD, Shipping Corporation of India on “Chahabar –India’s first Overseas Port Project” in Iran at a strategic location east of the Strait of Hormuz in the Gulf of Oman.

He covered the strategic importance of this port in the maritime connectivity of Afghanistan, Iran and Baluchistan in West Pakistan, and the land connectivity for trade through this port. Mr. Gupta also covered other port projects under discussion and development by Indian Government in the Indian Ocean region.

Cmde. KE Mathew, IN (Retd), Director (Shipbuilding), Hindustan Shipyard Limited, the Chief Guest for the Event, participated online from Vishakhapatnam. He congratulated the speakers for their excellent, topical and futuristic presentations of two different genres in the maritime field. He gave a brief outline of the presentations and their utility from his perspective.

The Technical session was concluded with a **vote of thanks** from **Dr. V. B. S. Ayyangar** of NSTL, Vizag.

MASSA Academy Chennai pioneers to deliver Gas fuelled Engine Course – launches FIRST ME-GI Course in India



As the maritime industry explores different approaches towards decarbonisation, dual-fuel engines are becoming increasingly prevalent in the build of new vessels since they are more environmentally friendly than other alternatives.

Owners are keen to install them to reduce vessels’ emissions

of greenhouse gases, and to comply with the environmental requirements, set forth by the International Maritime Organisation (IMO) for 2030 and beyond.

Paving the way for the maritime energy transition in shipping is the renowned MAN Energy Solutions which offers a dual-fuel engine that are specific to the type of fuel a vessel utilises.

Ship owners are increasingly using gases and low-flashpoint fuels to run their vessels on MAN ME-GI Dual Fuel Engines. That’s why there is an urgent need to train crew on the Operation

and Analysis of these modern Engines.

MASSA Maritime Academy in Chennai has commenced - for the first time in India – a **5 day ME-GI Dual Fuel Engine – Operation and Analysis Course**. This course is delivered online with access to Dual Fuel Engine Simulator from Cloud. It allows hands-on practical experience on the actual workings of the Dual-Fuel Gas injection Engine as well as fault finding and problem-solving.

Course Focus:

- Introduction to the ME-GI-DF (Gas Injection, Dual Fuel) engines

Turn to page -3 >>

ATPI MARINE & ENERGY



ATPI Marine & Energy is an international leader in providing travel to the energy and shipping sectors. Offering solutions tailored to offshore organisations, alongside 24/7 expertise and innovative technology, ATPI Marine & Energy operates with cost, efficiency and safety at the forefront of every travel strategy.

Delivering what really matters™

www.atpi.com

MARINE NEWS



"Failure is a lesson learned; success is a lesson applied."

MASSA Academy Chennai pioneers to deliver From Page : 2

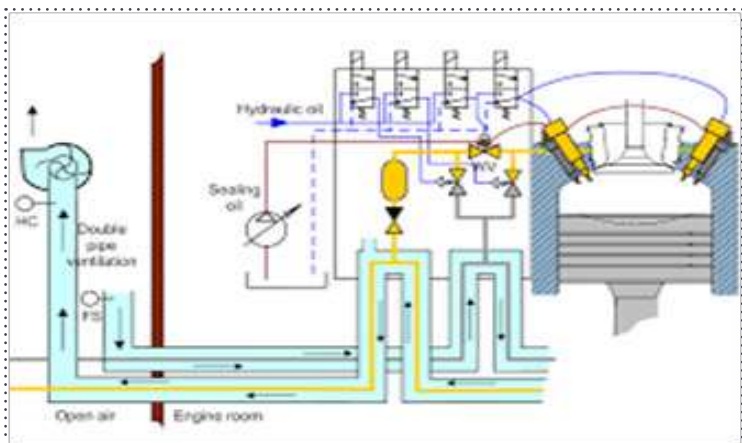

- Operation of the ME-GI-DF engine on LNG Ship (IGC Code)
- Operation of ME-GI DF engine on non LNG ship which are fitted for dual fuel operations.
- Effect of Green House Gases in Global Warming, Climate changes and Decarbonisation Initiatives (Paris Memorandum, IMO Tier 3 regulations).
- Awareness on bunkering

of LNG guidelines and associated precautions.

- The training course covers the vital engine systems, liquid and gas fuel, safety, electronic and hydraulic control system of the ME-GI-DF engine
- The ME-GI-DF engine training course is interactive, using a sophisticated MEGI simulator for practical exercises
- Practical fault-finding and problem-solving

Course structure: Online Course with access to ME-GI Simulator from Cloud for hands-on

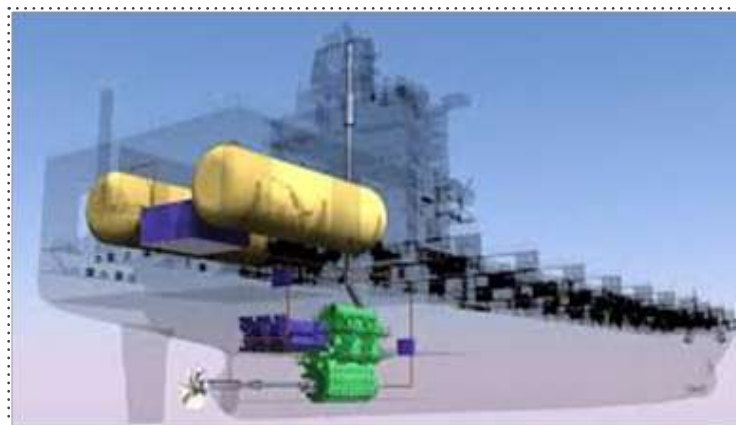

experience backed by Exercises, Assessments, and Lectures.

MASSA Maritime Academy in Chennai has already successfully completed 3 batches of this course with participants from top international companies comprising senior Engineers, Electricians,

and Technical Superintendents.

For further details and nominations please contact MASSA Maritime Academy, Chennai. Phone: 044 – 8807025336, 7200055336 E-Mail: mmachennai@massa.in.net Website: <https://massa-academy-chennai.com/>

After 50 days of travel, river cruise Ganga Vilas to reach its destination on February 28

DIBRUGARH
Sagar Sandesh News BUREAU

The World's longest river cruise 'MV Ganga Vilas' will culminate its journey on February 28th in Dibrugarh.

A welcome ceremony

will be organized by the Inland Waterways Authority of India (IWAI), under the aegis of the Ministry of Ports, Shipping and Waterways, Government of India in Dibrugarh on the same day.



The World's longest river cruise 'MV Ganga Vilas'

The event will be graced by Union Minister of Ports, Shipping and Waterways (MoPSW) Sarbananda Sonowal along with other Union Ministers, State Ministers, Diplomats and officials of IWAI and Ministry of Ports and Shipping. Dibrugarh is home town of the Union Ports Minister,

'MV Ganga Vilas' a cruise vessel began its journey from Varanasi on January 13th.

The Cruise has covered a distance of 3,200 km in over 50 days before

reaching Dibrugarh on the February 28th February via Patna Sahib, Bodh Gaya, Vikramshila, Dhaka, the Sunderbans and the Kaziranga national park. Built with a unique design and a futuristic vision, the cruise has three decks and 18 suites on board with a capacity of 36 tourists. It is already booked for to and fro journey for the next two years.

Mr Sonowal said "MV Ganga Vilas' has put India and Bangladesh on the river cruise map of the world thus opening a new horizon and vertical

for Tourism and freight carriage in Indian sub-continent.

Tourists seeking spirituality have the opportunity to visit destinations like Kashi, Bodh Gaya, Vikramshila, Patna Sahib and those keen on witnessing the natural diversity will cover destinations like Sundarbans and Kaziranga. This route heralds a new chapter for freight carriage through inland waterways both for India and Bangladesh. Now through this journey, tourists have an opportunity to go on board an immersive experiential voyage and explore the art, culture, history, and spirituality of India and Bangladesh along the entire route"

**For Advertisement
Please Contact :**

admin@porttoport.in

**9384484864 /
+91 72000 84864**



Mumbai Office
217, Secands Road, Unique Industrial Estate, off Veer Savarkar Marg, Bombay Dyeing Compound, Prabhadevi, Mumbai - 400025
Ph: 022 - 24211583 / 24210193. Fax: 022 - 2421 2149

Chennai Office
No.6, Nungambakkam First Lane (Opp. Regional Office, Indian Oil Corporation), Nungambakkam High Road, Chennai - 600 034
Ph: 044-42664408

Admin. Office
21 "LAKSHMI", Sathya Sai Nagar, Madurai-625 003. Ph : 0452 437 8300 / +91 72000 84864

EDITOR & PUBLISHER : **Dr R Lakshmipathy**
EXECUTIVE EDITOR : **Dr G.R. Balakrishnan, M.A Phd.,**

ADVISORY EDITORIAL BOARD

Mr. Ashok C. Advani,
Chief Engineer - Advisor (Mumbai) RLINS, Ex General Manager - Pacific International Lines.

Capt. S.S. Jairam,
Master Mariner, Ex Director- Seearland Management services Pvt Ltd. Ex Chairman - MASSA.

Captain S.M. Halbe,
Chief Executive Officer - MASSA; Fellow of Nautical Institute, London and CMMI, Ex MD- GEM.

Mr. Y. Nath, PFI.Mar.E., F.I.E.,
Chartered Engineer, President, Planmain Quality Consultants (India) Pvt. Ltd.

SAGAR SANDESH - Maritime Tabloid English Weekly Thrice E-Paper
Published by Dr R Lakshmipathy (Owner) on behalf of Professional Publications (P) Ltd, "Sriram", 27, Sathyasai Nagar, Madurai - 625 003.
Published at "Lakshmi", 21, Sathyasai Nagar, Madurai - 625 003, Tamilnadu.
RNI No. TNENG/2012/41759.

MARINE NEWS



“Failure is a lesson learned; success is a lesson applied.”

AMP Terminals: Vessel Inspection App gets sector seal of approval

New Delhi
Sagar Sandesh News Service

AMP Terminals' Vessel Inspection App has been relaunched this month with new features to further support safe working environments for stevedores and other terminal staff.

The app, which is available in six languages: Arabic, English, French, Georgian, Portuguese and Spanish, takes inspectors through a standardised eight-step procedure, ensuring consistent, comparable and tracked results.

Eight-steps to Safer

Inspectors are guided to



So far, 23,000 inspections have been carried out globally using the App

ensure the gangway is safe before they board a vessel, to inspect all relevant work areas and address concerns before operations start. By digitizing the inspection process, key concerns are reported consistently across vessels, and across terminals.

With the App, Pre-existing or historic issues are flagged and visible, and a scoring system from one to four (rather than the previous yes/no response) facilitates the rating of criticality. Further upgrades include training materials and

visuals guides to improve ease of use, and escalation steps in the event of safety critical or recurring issues. Standardized processes for managing critical risks have, as a result, been further enhanced.

So far, 23,000 inspections have been carried out globally using the App which has been credited with elevating safety Standards across shipping lines. The relaunched App has already received positive feedback from inspectors from our six pilot terminals.

No shortcomings

The App has attracted the attention of our joint venture and non-controlled APM Terminals partners. Additionally, it received the recent accolade

of being placed first in the industry-leading TT Innovation in Safety Awards on February 23.

Said Jack Craig, Chief Operations Officer at APM Terminals: “We are delighted with this recognition for the safety app we have developed in-house in collaboration with Maersk..”

His words were echoed by ArunKalam, Sr. Global HSE Business Partner, and member of the team responsible for the upgrade. **“Safety is the leading driver in this Application – and safety extends beyond competitor boundaries,”** he said.

“We want to make sure that the environment in which stevedores work is safe, and that all colleagues return home safely every day.”

Two Reported Missing as Tug Sinks in Scotland

New Delhi
Sagar Sandesh News Service

A rescue operation was launched Friday 24 Feb for two crew members after a tug capsized and sank in Scotland's East India Harbour.

The HM Coastguard reports

that the tug capsized off Custom House Quay in Greenock and is believed to have had two crew members.

“Just before 3.30pm Coastguard Rescue Teams from Helensburgh and Greenock, a lifeboat from Helensburgh RNLi and the Coastguard helicopter from

Prestwick were sent to assist and searched the area,” the Coastguard said in a statement.

“Multiple vessels on the Clyde in the vicinity of the incident also responded, including a MO Police vessel.

“The Coastguard's involvement in the surface search was terminated at 8pm.”



Photo courtesy Iain Cameron via Twitter

SHIPPING NEWS



SGS; Shipping's singular focus on alternative fuels to lower costs and GHG emissions ignores the most immediate renewable energy solution: Wind.

New Delhi
Sagar Sandesh News Service

New technologies make this established solution the best short term propulsion answer, says Diane Gilpin, CEO of Smart Green Shipping.

Shipping's green bullet

The ongoing climate emergency makes the need to reduce emissions from shipping more urgent than ever. The best way to lower emissions is to use less fuel onboard ships, which will also result in lowered fuel costs – and, if handled correctly, less operational complexity.

At present, maritime has an overwhelming focus on low-carbon fuels, with options such as LNG, ammonia and hydrogen being trialled onboard ships and discussed at forums such as the IMO. However, progress has been slow, the transition will be expensive and many shipowners are frustrated with a lack of clarity,

which leaves them vulnerable to stranded assets and unpredictable fuel cost risks.

While there is no single fuel that can replace HFO, there is a solution available in the very short term which will lower fuel costs and emissions – 21st-century retrofittable, autonomous wind-assist technology – which, according to a UK Department for Transport study is suitable for retrofitting onboard at least 40,000 commercial ships. Wind is an additional, free, clean power source for large merchant ships deployed as a hybrid energy solution.

This technology is not hot air. There is growing international support from individual investors (including shipowners) and also global governments. I speak from

personal experience. Smart Green Shipping, has received multiple tranches of funding from the UK government and private investors for our FastRig rigid wing sail and our TradeWind software tool.

This is not a marketing pitch, but rather evidence that 21st-century wind technology is user-friendly. ‘Wind 2.0’ as I like to call it is an affordable, technologically sound, commercially vetted solution that offers investors peace of mind about their assets as it will always go beyond compliance – and will play an important part in the fuel mix of the future.

Wind is, without a doubt, the fastest, cheapest way that shipping can reduce emissions in line with climate science.



A sailing ship is no democracy; you don't caucus a crew as to where you'll go anymore than you inquire when they'd like to shorten sail. - Sterling Hayden

Shipping Hedge Fund Says Industry Set For another Boom Year

New Delhi
Sagar Sandesh News Service

A shipping hedge fund founded by a one-time ally of oil tanker billionaire John Fredriksen says the industry is set for another boom year because of the reopening of China's economy and a lack of fleet expansion.

Tor Svelland, founder of Svelland Capital Ltd., a hedge fund that focuses on commodities and freight markets, says **the ingredients are there for a strong year for the ships that keep the global economy running — possibly even a record one.**

"We are under invested in shipping, so the majority of the market is struggling on the supply side," he said. As such, the merchant fleet's transportation capacity "isn't meeting demand."

Investors are watching closely for signs of how China's departure from its Covid zero policy will translate into real economic activity.

The vessels bringing in iron



Another boom year for the industry says shipping hedge fund

ore and coal to power industrial production, and oil for cars and trucks, offer insights into the pace of recovery. Likewise, container ships haul billions of dollars of manufactured goods from factories in China to consumers globally.

The ClarkSea index, a measure of average day rates across all vessel classes, averaged \$37,253 per day last year, a 30% hike year-on-year and the highest since at least 1990, according to data from Clarkson Research Services Ltd., part of the world's biggest shipbroker.

Numerous parts of the shipping industry are struggling with the supply of vessels, Svelland said.

EU targets shipping in latest package of Russia sanctions

New Delhi
Sagar Sandesh News Service

The European Union approved a tenth package of Russia sanctions on Friday 24 Feb with shipping very much in the sights of politicians.

Sun Ship Management, the Dubai-based manager of the Sovcomflot fleet, is part of the new sanctions as is the Russian National Reinsurance Company (RNRC) and Atomflot, which manages Russia's icebreaking fleet.

"Dubai has become a hotbed for companies controlling shadow tankers and the sanctioning of Sun Ship Management would



Sovcomflot

undoubtedly create more hurdles for Russia moving its barrels," BRS stated in a recent tanker report.

"Sun Ship has been operating as one of the key companies managing and operating the maritime transport of Russian oil," the EU said. "The Russian Federation is the ultimate beneficiary."

Sovcomflot set up Sun Ship Management in Dubai in 2012. The subsidiary was called SCF Ship Management (Dubai) until July. In April 2022, Sovcomflot transferred management of 92 of its tankers and LNG carriers to Sun Ship Management.

Regarding the decision to sanction state-backed reinsurer RNRC, the EU stated: "This reinsurance service offered by the RNRC has enabled the Russian Government to deflect and mitigate the impact of western sanctions on its oil trade."

The strong freight market last year wasn't universal. Rates for containers have fallen 80% from their mid-2021 peak during the pandemic when supply chains were snarled.

And that sector's outlook isn't so bright, as a slew of new ships entering the market help to stave off what has been a period of red-hot demand, he said.

Svelland said he's particularly bullish on the outlook for carriers that ferry commodities from grain to iron, even though rates are way down since the start of the year.

Oil and fuel tankers are also likely to have to travel further this year after the European

Union banned almost all seaborne purchases from Russia, forcing the country to send cargoes thousands of miles further to Asia. Likewise, Europe will have to import some of its supplies from countries further away.

"We will most likely see flows lengthen from both sides," he said. **The longer journeys mean a reduction in the availability of ships, unless more ships become available to the fleet.** Even after a record year, Svelland said he's bullish that freight rates will climb even higher on average across vessel classes, driven mainly by oil tankers, dry cargo and LNG. Freight rates should see some upside this year as long as there's no deep global recession, he said.

A Golden Opportunity for Engineering Graduates and Diploma Holders

A rewarding career in the Merchant Navy

ADMISSION Open For Feb-2023 -Batch-

Graduate Marine Engineering (GME)

- Eligibility : Degree in Mechanical Engineering / Mechanical and Automation / Mechanical and Electronics / Mechanical and Automobile / Marine Engineering / Naval Architecture / Naval Architecture and Ocean Engineering / Naval Architecture and Ship Building
- Age Limit : Maximum 28 years, Medical Fitness as per DGS Norms.
- Duration : 1 year (Fully residential)

Electro Technical Officer (ETO)

- Eligibility : Diploma / Degree in Electrical And Electronics Engineering / ECE / ETE / EIE or equivalent.
- Age Limit : Maximum 35 years, Medical Fitness as per DGS Norms.
- Duration : 4 Months (Fully residential)

For Admission Contact : 9894007317 / 7339132159 / 9489007317

R L INSTITUTE OF NAUTICAL SCIENCES

(Approved by Directorate General of Shipping, Ministry of Shipping, Govt. of India) | (Affiliated to Indian Maritime University, Chennai)

T.V.R. Nagar, Aruppukottai Road, Madurai - 625 022.

Ph : 7397788618 e-mail : rlins@rlins.in, admission@rlins.in web : www.rlins.edu.in

College Run By Joint Managing Editor Dinamalar, Daily News Paper



Coastal container feeder service to be launched between Chennai and Puducherry

New Delhi
Sagar Sandesh News Service

To be operated by the Chennai-based Global Logistics, the 12-hour ferry service is expected to help the trade avoid the congested road traffic and take delivery of boxes through Direct Port Delivery (DPD) and Direct Port Entry (DPE) than using storage spaces like Container Freight Stations (CFS) and Inland Container Depots (ICD).

The Chennai Port Authority (CPA) and Puducherry port signed a memorandum of understanding in 2017 for the



In a first of its kind in the country, a short-haul coastal container feeder service will be launched on Monday 27 Feb between Chennai and Puducherry ports.

diversion of cargo to the latter and sharing of revenue.

Sunil Paliwal, Chairman, CPA, will flag off the operations offered by Global Logistics from DP World

Container Terminal inside the Chennai port on Monday morning.

The overall freight cost could be reduced by 25 per cent by moving through sea as against the road movement (160 km), said an industry official.

The service will help the trade in the hinterland of Puducherry as DPD and DPE-cleared containers can be moved easily since no clearance is required in the Puducherry port, said S Narasimhan, Managing Director, Sattva ICD at Puducherry. **The Government of Puducherry should make sure that the city does not become congested, he added.**

AV Vijayakumar, Managing Director and CEO, Paramount Shipping Service Pvt Ltd, says that it is an innovative concept of the business model but will take time for the industry to shift its existing

comfort zone where the box is picked up and delivered at their doorstep.

Unless cost-effectiveness is established, this could not be a lucrative model, and feeders will drop boxes at ports and there is a last leg connectivity to the importer/exporter at an additional cost and time. Looking at the larger picture, this will reduce density on the roads, fewer carbon footprints, and be more eco-friendly. DPD/DPE could be a potential business, which can be easily grabbed if there is an aggressive strategy.

The sailing time between the ports could be half a day.

Two advantages can be expected – cost savings and Greenhouse Gas emission reduction – as it is proven that water transportation emits less CO2 than the road and also ease out the congestion on the road.

PORT NEWS

New Delhi
Sagar Sandesh News Service

Government of India has recognised the economic and environmental benefits of coastal shipping under the vision SAGARMALA and modal shift from road mode.

In this regard, it is decided to develop Pondicherry Port as Satellite Port to Chennai Port for container cargo— Exports and Imports from and to Puducherry and its hinterland extending to Cuddalore / Nagapattinam in South East, Trichy / Villupuram in South, Salem / Namakal in West.

In this regard, a Memorandum of Understanding between Chennai Port and Pondicherry Port was signed on 15.03.2017.

The commercial cargo handling operations could not commence immediately due to change in

Inauguration of Container Feeder Service from Chennai Port to Pondicherry Port



Mr. Sunil Paliwal, IAS, Chairperson, Chennai Port Authority Flagged off Container Feeder Ship

weather conditions resulting in siltation at the mouth of the Pondicherry Port

In order to mitigate the siltation problem and to develop Pondicherry Port, deepening of sea mouth entrance at Pondicherry Port was undertaken and the work is completed.

The Salient features of Feeder

Service between Chennai Port to Pondicherry Port are:

- Quick direct transit to terminal at Chennai and Pondicherry Ports.
- Pondicherry Port is Customs ICEGATE enabled with Quick Import and Export clearance facility with efficient in port warehouse containing stuffing and de-stuffing facility at Pondicherry.
- Economical all sea route passage providing quick onward connection Chennai Port for Export and Import containers.
- Eliminates road congestion and pollution
- Accepts Hazchem & DG & Class C cargo in Containers
- Accepts Reefer containers

- Ship is with a container Crane – Gearing Vessel.
- Reduction in container transportation charges.

It is expected to increase the volume of cargo from Pondicherry and its hinterland without road congestion to Chennai Port.

The Union Territory of Puducherry will witness tremendous industrial growth in the coming years resulting in increased investment by major industries in the Union Territory.

The event was headed by Shri Sunil Paliwal IAS, Chairperson and Shri S. Balaji Arunkumar IRTS, Dy. Chairperson, Chennai Port Authority. also present - by Shri Jude and other officials of Chennai Port, DP world, and Global Logistics

Chairperson, Chennai Port Authority Flagged off Container Feeder Ship – HOPE SEVEN with the container capacity of 106 TEUs at DP World Container Terminal, Chennai Port to Pondicherry Port on 27.02.2023.

NEWS IN BRIEF

(To Read Full News Please go to www.sagarsandesh.in)

Puducherry to get connected by air to Tier 2 and 3 cities in Tamil Nadu

In another few months you can fly from Puducherry to various tier 2 and Tier 3 towns in Tamil Nadu beside Chennai and Bengaluru



Govt plans 10 'Clean Plant Centres' to boost fruit crop production

WITH THE demand for foreign planting materials of fruits like apple, avocado and blueberry rising over the years, the Centre plans to set up.....



SCINNTC Supply Chain Solutions (NTC Group) Commissions a State-of-the-art Warehouse facility in Gujarat for Gulf Oil Lubricants

SCINNTC, a subsidiary of NTC Group is pleased to announce the inauguration of India's amongst few lubricant compliant warehouse at its state-of-the-art distribution Centre (CDC).....



PORTS (REGIONAL/INTERNATIONAL)



“News is what somebody somewhere wants to suppress; all the rest is advertising.” - Lord Northcliffe

MoPSW Secretary Sudhansh Pant directs VPA to speed up cruise berth works



Ministry of Ports, Shipping and Waterways Secretary Sudhansh Pant at the Visakhapatnam Port Authority (VPA)

New Delhi
Sagar Sandesh News Service

Ministry of Ports, Shipping and Waterways Secretary Sudhansh Pant has directed

the Visakhapatnam Port Authority (VPA) to speed up the works of the cruise berth in the outer harbour at the earliest as it is the prestigious project of the Union government.

He visited VPA and Dredging Corporation of India Limited (DCI) on Saturday 25 Feb for reviewing the performance of the companies. VPA and DCI Chairman K. Rama Mohana Rao co-ordinated the review meetings.

Mr. Pant focused on the operations of PPP berths and Green Port initiatives by the VPA during the review meeting.

The port authorities presented a PowerPoint presentation to show the status of cargo handling, financial performance of VPA, road, rail connectivity, capacity augmentation, modernisation and mechanisation of berths, development of flyover, truck parking terminal, construction of covered storagesheds, electrification of VPA railway tracks, modernisation of fishing harbour and status on NLP marine portal.

Paradip Port Handles Over 116mn MT of Cargo Well Ahead Of End of This Fiscal

New Delhi
Sagar Sandesh News Service



Paradip Port

The Praradip Port Trust has achieved a significant milestone in cargo handling. Addressing a Vaartalap- Media Workshop organised by Press Information Bureau at the port town of Paradip on Sunday 26 Feb , the Chairman of the Paradip Port Trust PL Haranadh said the port has handled more than 116 Million Metric Tonnes of cargo well ahead of the end of this fiscal.

Speaking on the occasion, he said the port has exhibited a positive growth of 17.5%, which

is the highest among all major Ports in the country.

Paradip Port Is vying for the coveted 130 MMT Cargo handling mark in the current fiscal itself, he added. Describing the Gatishakti initiative of the Union Government as a game changer in the country’s logistics landscape, Mr Haranadh said the port will stand to gain immensely from this initiative.



ALBION MARINE SOLUTIONS
TRUSTED ENGINEERING PARTNER



ALBION ENGINEERING INDIA PVT. LTD.
(Subsidiary of Albion Marine Solutions, Canada)
2/1 & 2, 1st Cross Street, Indira Nagar Adyar, Chennai – 600020.

For further details please contact

URL: www.albionmarine.com
Email ID: info@albionmarine.com
Mob: +91 9976378279

Albion provides the Ballast Water Sampling Services for VGP and IMO - D2, Approved by ABS and LR Class. BWTS sampling can be carried out globally.

- ❖ 24/7 availability in your nearest port
- ❖ The lowest price for the highest service
- ❖ Expertise in all makes of BWTS
- ❖ Compliance Certificates
- ❖ Excellent Customer Service

The unique combination of our operational experience and engineering expertise are the added advantage to our customers

PORTS (REGIONAL/INTERNATIONAL)

"News is what somebody somewhere wants to suppress; all the rest is advertising." - Lord Northcliffe

New Delhi
Sagar Sandesh News Service

During her visit, VPA Chairman K. Rama Mohana Rao, explained the infrastructure facilities available in VPA, the process of exports and imports, cargo handling capacity, modernisation and mechanisation of VPA Berths, the port said in a release.

The Special Secretary discussed the status of the Rail, Road and evacuation infrastructure, development of multi-modal logistics for Visakhapatnam Port undertaken through the PM Gati Shakti initiatives.

She also discussed the Container Terminal's operational performance captured under the Logistics Data Bank (LDB) Project.

Ministry of Commerce Special Secretary, Logistics visits Visakhapatnam Port Authority



Sumita Dawra, Special Secretary, Logistics, Ministry of Commerce, visited Visakhapatnam Port Authority (VPA) here on Friday 24 Feb. Mr. K. Rama Mohana Rao, Chairman, VPA, welcomed the Special Secretary.

Adani Ports Crosses 300 MMT of Cargo Handling In 329 Days



Mundra port

New Delhi
Sagar Sandesh News Service

Adani Ports & Special Economic Zone said that it surpassed 300 metric million tonnes (MMT) of cargo handling on February 23, 2023, in just 329 days, beating its own milestone from last year of 354 days.

India's largest operator of commercial ports reported a 4 per cent year-on-year growth at its container terminals.

"The improvement in cargo volumes is testimony to the faith that our customers have in us," said Karan Adani, CEO and Whole Time Director, APSEZ. "It shows our commitment to using improved efficiencies and technological integrations to drive and achieve customer satisfaction. The APSEZ's flagship port,

Mundra, is outpacing all its closest rivals by comfortable margins and continues to be the largest port in the nation in terms of volumes handled. Mundra's infrastructure meets world standards and provides service levels on par with those of its global competitors, making it India's gateway for container goods."

Mundra Port saw an increase in RO-RO exports of 18 per cent, mostly due to long-term

customer Maruti Suzuki India Limited. "Due to its proximity to India's chemical industry, Hazira has seen consistent year-on-year development in chemical quantities. This year has witnessed a 16 per cent increase," the company said in a press note.

Mundra Port delivered 1,501 fertiliser rakes in the current fiscal year, with a total cargo dispatch of 4.8 MMT.

Shares of Adani Ports and Special Economic Zone (Adani Ports) gained nearly 1 per cent after the company announced that the consortium of Adani Ports and Israel's Gadot Group has completed the acquisition of HPC from the government of Israel.

Adani Ports had on July 15 last year announced that the consortium of Adani Ports and Gadot Group with 70:30 shareholding had won the competitive bid for the privatisation of HPC at an offer price of \$1.18 billion.

The concession period of the port was up to 2054.

Meanwhile, Adani Group has also pre-paid Rs 1,000 crore short-term debt in order to regain the investors' confidence. Adani Group had faced severe criticism after a fallout with a US short seller's scathing report.

Transit through Iran's northern ports rises 70%



Photo: PMO Head Ali-Akbar Safaei (3rd L) and PMO Deputy Head Jalil Eslami (2nd L) at the annual meeting of the organization's managers

New Delhi
Sagar Sandesh News Service

Head of Iran's Ports and Maritime Organization (PMO) has said transit of goods through Iranian ports along the Caspian Sea has increased by 70 percent in

the current Iranian calendar year (started on March 21, 2022), the PMO portal reported.

"The traffic of all kinds of foreign goods to the country's commercial ports this year has increased between eight and 10

percent compared to the same period last year, and at the same time, we were able to record a 70 percent increase in transit from the Caspian Sea ports," Ali-Akbar Safaei said on Saturday at an annual meeting of the PMO directors.

According to Safaei, the total volume of the export, import, and transit through the country's ports is expected to exceed 210 million tons by the end of the current Iranian year (March 20).

Referring to the PMO's positive collaborations with the International Maritime Organization (IMO), Safaei emphasized: "The Islamic Republic of Iran, as one of the effective members of IMO, plays an effective role in the formation of new maritime regulations and laws."

NEWS IN BRIEF

(To Read Full News Please go to www.sagarsandesh.in)

Pune Software Engineer Uses Hydroponics to Grow Saffron in Shipping Container

History has been witness that India's spices are worth wars. A special spice that the country has to offer is saffron,



PORTS (REGIONAL/INTERNATIONAL)

"News is what somebody somewhere wants to suppress; all the rest is advertising." - Lord Northcliffe

Invest in the next growth story at JNPA SEZ

New Delhi
Sagar Sandesh News Service

Jawaharlal Nehru Port Authority (JNPA), India's premier container port has developed India's first port-based multi sector operational Special Economic Zone (SEZ) in its vicinity.

To showcase unmatched growth propositions that it offers, JNPA SEZ in association with the Confederation of Indian Industries (CII) organised a JNPA SEZ Investor Conclave from 1630 hrs on Friday, February 24, 2023 at The Radisson Blu, Nashik.

The JNPA SEZ Investor Conclave succeeds impactful editions in Mumbai and Surat. It was based on the theme 'Invest in the Next Growth Story'.



Shri Sanjay Sethi, IAS, Chairman, JNPA

The Conclave featured addresses and presentation focussing on the key aspects of the JNPA SEZ while a panel discussion on 'Potential and Opportunities with JNPA SEZ' offered insights on 'Achieving Global Standards with Sustainability'.

These deliberations provided an inclusive

overview about the reasons for investing in JNPA SEZ and with a focus on meeting global parameters in Sustainability.

Leading stakeholders from the Industry, JNPA Management and the Government participated in these discussions and shared their insights.

Stating that the conclave

proved to be a boon for those seeking to invest in Maharashtra, Shri Sanjay Sethi, IAS, Chairman, JNPA, said, "Aligning with the clarion call of 'Make in India' given by our Hon'ble Prime Minister Shri. Narendra Modi, JNPA has been at the forefront of promoting local trade and providing the best platform for nurturing such business. After our stupendous success at Mumbai and Surat, we wanted people from other parts of Maharashtra such as Nashik to take advantage of the available facilities at JNPA SEZ."

"With the commissioning of the first phase of Hindu Hrudaysamrat Balasaheb Thackeray Maharashtra Samruddhi Mahamarg and Delhi Mumbai Expressway, reaching JNPort has become economically viable for traders. Due to this, the state has been at the

top of the list of investors. JNPA SEZ is committed to provide them the best available infrastructure and facility to carry out the trade and enliven the dream of our Prime Minister to make India an economic powerhouse," the JNPA Chairman added.

NEWS IN BRIEF
(To Read Full News Please go to www.sagarsandesh.in)

Talks on regarding long-term contract at Chabahar port: Sarbananda Sonowal



India and Iran are negotiating terms of the main contract on long-term usage of

OUR TUTICORIN BRANCH IS CELEBRATING 25TH ANNIVERSARY OF OUR SERVICE TO THE EXPORT AND IMPORT TRADE .

WE THANK ALL THE EXPORTERS, IMPORTERS, PORT / TERMINAL & CUSTOMS OFFICIALS, SUPPORTERS IN SHIPPING AND LOGISTICS TRADE FOR THE TRUST YOU HAVE PLACED IN US.



Triway group
"we know your requirements"
Since 1994



SERVICES

- * Customs Broker
- * IATA Agent
- * CFS Operator
- * Warehouse Operator
- * Freight Forwarder
- * ODC / Fleet Service

BRANCHES

- Bangalore
- Coimbatore
- Tirupur
- Mumbai

Corporate & Registered Office

No. 325, Thambu Chetty Street, Chennai - 600001.

Ph : 044 - 40924092, Email : chennai@triway.in www.triway.in

TUTICORIN OFFICE

No.5/123A, 2nd Street, Caldwell Colony, Tuticorin - 628008.

Mr. D. Kumar (Branch Incharge)

Mobile : 9940077907 Ph : 0461 - 2375294, 2375312 Email : dkumar@waymark.in



TRADE BODY NEWS



"Worrying will never change the outcome"

Transport workers keep Ukraine moving: ITF

New Delhi
Sagar Sandesh News Service

"Even in the eye of the storm, amid this invasion with a big target on their back, transport workers have kept Ukraine moving," said ITF's Paddy Crumlin.

In the last year railway workers have evacuated four million Ukrainians by rail, including getting over a million children to safety. **Ukraine's dockers have shipped vital grain supplies to feed the world and support Ukraine's economy.** Ukrainian seafarers, critical to the operation of global supply

chains, have sent home much-needed funds to families and communities disrupted by war.

Ukraine's ports, railway lines, and road supply routes: effectively the workplaces of transport workers, have been a consistent target of military forces.

"Transport workers have been under particular threat during this conflict," said Crumlin. "With confirmed and unconfirmed reports of civilian transport infrastructure being targeted by military intending to shut down or seizing control of these assets," he said.

Some docks have reopened, primarily in the south, and almost exclusively to handle grain. They do so under the protection of the United Nations' Black Sea Grain Initiative. Russia's shaky adherence to the trilateral agreement with Ukraine and neighbour Türkiye leaves dockers and crew aboard visiting ships mindful that their workplace could be a warzone at any moment.

Unions renewed calls for everything possible to be done to end the war in Ukraine. **"The world is in chaos, but it's not because of transport workers. We have kept**



Ukrainian and Filipino crew aboard the ship 'Regina Oldendorff' showing their support for peace.

our end of the social contract – it's now for national leaders need to do their job and secure lasting peace," said ITF's Cotton.

Cotton said: "All parties, including Russia and Ukraine, as well as

across Europe and the NATO States, must do all in their power to de-escalate tensions and seek a peaceful, diplomatic end to this crisis. The UN must play its part to brokering talks. There can be no peace without dialogue."

TERMINAL NEWS



Chennai Port Maduravoyal elevated corridor

CHENNAI
Sagar Sandesh News BUREAU

With National Highways Authority of India (NHAI) receiving the clearance from the Chennai division of the Southern

railways for the drawings of the two flyovers last week, the last hurdle for the resumption of work on the Chennai Port- Maduravoyal elevated corridor project after a span of 12 years has been overcome. By all indications,

Work on the project is expected resume by May this year.

Chairman of the Chennai Port authority Sunil Paliwal announced this at a news conference got up to inaugurate the first cargo service between Chennai port and Puducherry at the port premises on February 27th.

He said the all important coastal regulation clearance for the project

Work on Chennai Port Maduravoyal elevated corridor project all set to resume by May.

was received in January this year. The Chennai divisional manager of the southern railway has cleared the drawings for the two flyovers that would be built as part of the elevated corridor last week.

Tenders will be called to identify the PPP contractor who will implement the project on March 8th. It would take at least a month to evaluate the tenders. In all Likelihood work on the project may resume by May this year. Meanwhile the Union Highways

Minister Nitin Gadkari had issued two official statements saying that the elevated corridor project of the Chennai Port will be completed by middle of 2024. Industry sources said this deadline set by the Minister will be too hard to achieve since hardly 12 months are left between now and the deadline date.

The project is being jointly executed by National Highways authority of India, Chennai Port and the Tamil Nadu government.

Delhi-Meerut RRTS

New Delhi
Sagar Sandesh News Service

The first trial of the Duhai-section is already completed, and very soon the corridor will become operational.

While the speed of the RRTS is one of its strong attributes, **the stations and coaches of the system will also be fitted with modern-day features for increased convenience.** As revealed in a report, there will be designated spots for wheelchairs and stretchers in the train coaches. Also, platforms will have large screens for information, along with dedicated pick-up and drop zones. The first corridor on the system to

LOGISTIC NEWS



RRTS is the next big thing in the National Capital Region.

become operational will connect Delhi and Meerut.

The stations of the Duhai Depot-Sahibabad section of the RRTS corridor are now getting adorned with the RRTS' signature blue facades, while several new features are being installed inside the train as well as at the stations.

The National Capital Region Transport Corporation (NCRTC) carried out another trial run in the Duhai Depot-Sahibabad section on Friday 24 Feb to test various components of the RRTS.

In a bid to enhance accessibility for commuters and help passengers safely cross over busy roads such as the Link Road and the Delhi-Meerut Road, the NCRTC is constructing the entry and exit points of the elevated stations on the RRTS corridor on both sides of the roads. **The entry and exit points will be accessible not just to the RRTS passengers but also to pedestrians who can use them to cross major roads without entering the paid area of the RRTS stations.** This feature will help in the safe movement

of pedestrians and also in crowd management at the stations. According to the officials, most of the RRTS stations have three to four floors and multiple elevators and escalators are being installed.

Platform screen doors (PSDs), which will be equipped with double-tempered glass and will act as a shield for safety between the trains, the track and the passengers, are also being installed at the RRTS stations. **The PSDs are being integrated with the RRTS train doors and a state-of-the-art ETCS Level-2 signalling system.**

In a bid to ensure easy access to the station, **a dedicated pick-up and drop-off zone at the stations and an additional drive-in space for all types of vehicles will also be built.**



Gujarat closes in on Tamil Nadu's leadership position in wind power race

New Delhi
Sagar Sandesh News Service

Tamil Nadu has been at the forefront of harnessing renewable energy, including the wind energy, over the last two decades. However, with faster capacity additions in recent months, favourable policy and support measures, the western State is likely to snatch the leadership position from Tamil Nadu soon.

At the end of March 2021, Tamil Nadu's total wind capacity was 9608 MW, while Gujarat's

capacity was nearly 1,000 MW lower at 8562 MW.

However, by the end of January, 2023, Gujarat's total wind power capacity rose to 9,919 MW, while Tamil Nadu's installed wind energy capacity stood at 9964 MW.

In the current fiscal, Gujarat has added 710 MW, while Tamil Nadu's addition was just 99 MW.

Tamil Nadu's share of wind power in its total renewable energy capacity has fallen from 65 per cent in FY21 to 59 per cent in January



Gujarat is on the verge of overtaking Tamil Nadu as the country's top State in terms of wind power capacity installation.

2023. This fall can attributed to the late offtake of most allocated tenders, said Hetal Gandhi,

Director-Research, CRISIL Market Intelligence and Analytics.

Gujarat has moved up in overall renewable power capacity addition too. A year ago, Tamil Nadu was the leader in total renewable energy capacity (15,914 MW), while Gujarat was at the third position (15,518 MW) behind Karnataka (15,463 MW).

However, the Government of Tamil Nadu is undertaking several policy measures to accelerate new capacity addition and has prioritised this as part of its Climate Mission launched in December 2022.

The State has so far harnessed only one-tenth of its wind power potential.

Warehousing as a Service' for brands, manufacturers & retailers across industries

New Delhi
Sagar Sandesh News Service

Ekart, India's largest supply chain network, will now make its warehouses across the country available to brands, manufacturers, retailers and SMEs as a part of its vision to become a 4PL (fourth-party logistics) player in the country.

The initiative will enable brands of all sizes, manufacturers, and retailers from across industries to leverage Ekart's technologically advanced fulfilment centres for flexible, affordable, and scalable inventory storage solutions, said a release.



Warehousing a service, says Ekart

The end-to-end warehousing services by Ekart will include ready-to-use best-in-class warehousing space, order management, integrated logistics and inventory management, further helping brands scale their business. Ekart will also offer specialised facilities such as temperature-controlled storage and storage for high-value inventory for businesses in need of these requirements.

Ekart has a pan-India supply chain network spread across more than 20 million sq. feet.

To begin with, it will offer

four dedicated sites across Bilaspur in Haryana, Malur in Karnataka, Saidham in Mumbai, and Uluberia (West Bengal), as well as 17 shared sites across India to businesses of all sizes. The expansive warehouses will ease the fulfilment process of orders for customers by helping reduce the transit time and better delivery speed. The state-of-the-art, Grade-A fulfilment centres are equipped to facilitate the safe and speedy delivery of orders.

Ekart's capability to handle 80+ product categories will also now be available to the brands, the release added.

VESSEL SCHEDULES

For the benefits of our Readers the Schedules will be available in the form of a comprehensive map with a hyperlink to the web portals of Respective Ports and their Terminals.

To know the details for any Port or Terminal, You are just required to log on to www.porttoport.in and click the tool vessel position / Ports and terminal.



WEST COAST	
AMCT	- Adani Mundra Container Terminal
AICTPL	- Adani International Container Terminal Pvt. Ltd.
MICT	- Mundra International Container Terminal
ACMTPL	- Adani CMA Mundra Terminal Pvt. Ltd.
KICT	- Kandla International Container Terminal
NSICT	- Nhavasheva International Container Terminal
NSIGT	- Nhavasheva International Gateway Terminal
JNPCT	- Jawaharlal Nehru Port Container Terminal
GTI	- Gateway Terminals India
BMCT	- Bharat Mumbai Container Terminals
ICTT	- International Container Transshipment Terminal

EAST COAST	
VCTPL	- Visakha Container Terminal Pvt. Ltd.
KPCT	- Krishnapatnam Port Container Terminal
CCT	- Chennai Container Terminal Pvt. Ltd
CITPL	- PSA's Chennai International Terminals Pvt Ltd
KICT	- Kattupalli International Container Terminal
DBGT	- Dakshin Bharat Gateway Terminal Pvt. Ltd.
PSA SICAL	- PSA SICAL Terminals Limited



"News is what somebody somewhere wants to suppress; all the rest is advertising." - Lord Northcliffe

EXIM TREND

Germany assures India that a Free Trade Deal with European Union will happen

NEW DELHI
Sagar Sandesh News BUREAU

German Chancellor Olaf Scholz has said he and his Indian counterpart were committed to making a free trade deal between India and European Union finally happen.

(The deal has been hanging in balance for over two decades due to differences in approach between the two countries)

It's an important topic and I will get personally involved," Scholz said after a meeting with Prime

Minister Modi at Hyderabad House in New Delhi.

Talking about the bilateral relations, Scholz said **he and PM Modi have similar ideas and they have been cooperative and discussing matters.**

On job creation, the chancellor said that **about 1,800 German companies are active in India and have provided thousands of jobs**, adding that Germany also wants to benefit from Indian talent.

"We need talent, we need skilled workers. The development of IT



German Chancellor Olaf Scholz and PM Modi

and software is booming in India and many capable companies are here in India. India has so much talent and we want to benefit from that corporation. We want to recruit and attract that talent in Germany," he said.

Addressing the joint conference, Prime Minister Modi underlined the deep understanding and trust between the two countries. "Apart from being our largest trading partner in Europe, Germany is also an important source of investment in India.

The strong ties between India and Germany are based on shared democratic values of each other's interests," he said. "People-to-people relations have greatly improved between the two countries, in the last few years. Today, new opportunities are opening up in all sectors due to the 'Make in India'. We are encouraged by Germany's interest in these opportunities.

US favors new approach to India to build cooperation

BENGALURU
Sagar Sandesh News BUREAU

United States has called for a new approach to strengthen cooperation with India called the friend shoring to bolster the resilience of supply chains between the two countries.

As we look towards the future, United States is eager to deepen its ties with India in the technology sector. It is advancing an approach called "friend shoring" to bolster the resilience of our supply chains. We are doing this by strengthening integration with our many trusted trading partners, including India. We are seeing progress; as an example, technology



US Treasury secretary Janet L Yellen

companies like Apple and Google have expanded their phone production in India," US Treasury secretary Janet L Yellen said.

Ms. Yellen said this while addressing a roundtable with US and Indian tech business leaders

on the sidelines of the G20 Finance Ministers and Central Bank Governors Meeting in Bengaluru on February 25th

President Biden has said, **India is an indispensable partner to the United States.** The US is India's

biggest trading partner. In 2021, our bilateral trade was over 150 billion US dollars. Our people-to-people ties affirm the closeness of our relationship. 200,000 Indians are studying in America and enriching our schools and universities. We depend on each other on a daily basis: Indians use WhatsApp to communicate and many American companies rely on Infosys to operate," she said.

The roundtable was attended by top tech honchos, including Infosys chairman Nandan Nilekani, IBM India managing director Sandip Patel, Intel India country head Nivruti Rai, Foxconn India Country Head Josh Foulger and Wipro chairman Rishad Premji.

Through the Partnership

for Global Infrastructure and Investment or PGII, she said, the US is investing in digital technologies that will drive inclusive, resilient growth in India.

Under PGII, she said, the United States has announced investments in agri-tech to enable climate-smart agricultural production, and in digital payments systems for micro entrepreneurs.

These stand alongside investments in renewable energy, health, and other infrastructure sectors in India, she said, adding, the United States aims to mobilize 200 billion US dollars through 2027 for PGII and **looks forward to partnering with India to continue investing in its future.**

Gujarat HC issues notice against RoDTEP denial to sugar exporters

New Delhi
Sagar Sandesh News Service

The Gujarat High Court has asked the Centre and the tax authorities to file responses on petitions challenging the denial of benefits to sugar exporters under the neutralisation scheme.

The move pertains to a writ petition filed by some sugar



Gujarat High Court

exporters challenging the Customs authorities' step to recover benefits under the Remission of Duties and Taxes on Exported Products (RoDTEP).

The Customs department had issued several notices seeking deposits of refunds claimed by sugar exporters under the scheme.

It felt that sugar was not eligible for export quotas as it is a restricted commodity. However, the exporters moved the Court arguing that the scheme was not an additional benefit and should be applicable to exports even if they fall under the restricted category.

The matter will be heard next in March, as per a report.